

New Products from S&R Controls

Model D48 Pump Control Panels



This duplex pump control panel is designed with many of the functions offered on high-end custom controls system, but as standard on the D48. The control system includes a Type 4X rated enclosure with an inner door maintaining a safety barrier between the operators and the high voltage components during normal operations.

S&R Controls is currently offering the D48 for several pumping applications including;

- Lift Stations
- Water Booster Systems
- And Water Retention Systems

Each system will include the standard functions of the D48 and will include S&R Controls standard one year / 18 month warranty.

S&R Controls uses high-grade industrial hardware to manufacture the D48 panel to insure years of trouble free and reliable operation. All of the hardware used in the control system is available from most of the national electrical distributors. The switches are 22mm IP65 Type 4 operators with replaceable contacts and LEDs. Motor contacts are 3-pole IEC with class 10 ambient-compensated thermal overload relays per motor.

The D48 Pump Control Panel can be shipped from S&R Controls within 48 hours of the acknowledged receipt of order. (Note some of the options may require additional time.)

To order your D48 Pump Control Panel just complete the Panel Order Form on the back side of this letter and fax or e-mail to S&R Controls for your order acknowledgment. The standard shipping schedule will be 48 hours after ARO. (Based on normal business week of Monday through Friday.)



Standard Functions on all D48 Pump Panels

- Hand-Off-Auto per pump
- Green LED Run Light per Pump
- Total Pump Running Hours per Pump
- Pump Alternation
- Float Indication
- Pump Fault Indication
- Automatic Transfer Lead Pump Operation on Pump Fault
- Optional Pressure and Level Transmitter Control and Readout
- Dry Contacts for Remote Alarm Indication
- UL508A
- Options for Additional Functions (See reverse side)

Model D48 panel is available for shipment within 48 hours of the acknowledged receive of order.

Panel order form; Check the appropriate box and fax or e-mail to S&R

Fax: 877 217 8021

e-mail: sales@panelsbySR.com

Model Number

D48 - 3 - - - -

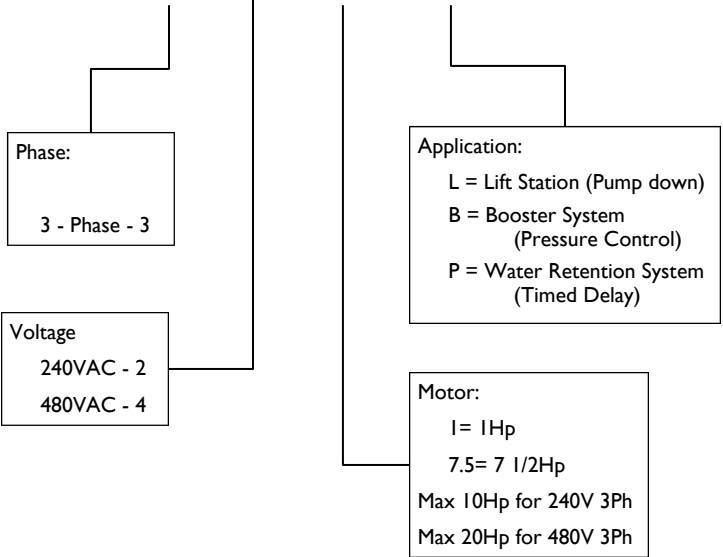

Example: Duplex pump system with 3Ph 240Vac 7.5 HP motors for a Booster System with pressure transmitters and alarm horn.

D48 - 3 - 2 - 7.5 - B Option: 3 & Both 4

Options

- 1. Add Main Power Non-Fused Disconnect with handle through the inner door.
- 2. Top Panel Red Alarm Light
Lift Station: High Level, Pump Fault
Water Retention: Pump Fault
Booster: Pump Fault
Low Suction Pressure
- 3. Alarm Horn with Silence Switch (same alarming conditions as Alarm Light)
- 4. Pressure Transmitters for Booster and Irrigation Systems (mounted on panel)
 - Suction 0-200 psi
 - System 0-200 psi
- 5. Level Transmitter (shipped loose)
0-30 ft submersible w/ 50 ft cable
- 6. Seal Fail Relays per Pump

Request From:

Name: _____

Company: _____

Phone Number: _____

E-mail: _____



Setting the Standard for Controls

Office phone: 972 271 5203
Toll free: 877 271 5253